

Problems	Possible Cause / Solution
1. Player not working or stopped working	<ul style="list-style-type: none"> • Unplug the power connector wait 30 seconds then plug it back in. make sure the connector is plugged in securely. Be sure to observe the Green LED light turns ON. • Be sure MX9000 card is inserted all the way into it's slot securely
2. No audio	<ul style="list-style-type: none"> • Check audio cord; try re-inserting it again, adjust the volume on player clockwise if needed to hear it. • Be sure MX9000 card is inserted all the way into it's slot securely
3. Audio quality is poor	<ul style="list-style-type: none"> • Verify that the audio cord is plugged in securely Make sure the audio volume is not too loud, adjust the volume control counter clock wise to correct the problem. • Set Volume to Medium.
4. Audio not loud enough at highest volume	<ul style="list-style-type: none"> • Make sue the problem occurs on any phone not just one of the phones • On some PBX phone systems you may need a higher output level model such as model SX9200



User Manual
AudiImage™ SX9000 Rev 01
Digital Audio System Player

- Insert the MX9000 “True Audio Card” into the slot as shown (be sure to insert the card all the way into the blue connector)
- Plug one end of the RCA audio cable into the Red RCA connector of Player, Plug the other end of the audio cable into your PBX phone system RCA connector usually labeled as “MOH”. If you have regular Non-PBX telephones, plug the other end into the Music-On-Hold adapter “Audio In” RCA connector instead.
- Set the Volume to ¾ up by rotating the Volume control on the Player clock wise as shown.
- Plug the included AC adapter. (110V AC to 9V AC)

Warranty

This product is warranted against defects for a period of Three (3) years from the date of original invoice. We will repair/replace the product with no charge for parts or labor within this time. To obtain warranty service the product needs to be returned freight prepaid by the customer with a copy of original invoice. This warranty does not apply if in the sole opinion of Innovative Telecommunication Technology, the product has been tampered with or damaged by lightning or any other acts of nature, misuse, neglect or unauthorized service.

EXCEPT AS SPECIFICALLY PROVIDED IN THIS AGREEMENT, THERE ARE NO OTHER WARRANTIES, EXPRESSED OR OTHERWISE, INCLUDING, BUT NOT LIMITED TO ANY IMPLIED WARRANTIES OR MERCHANTABILITY OR FITNESS FOR A SPECIAL PURPOSE. IN NO EVENT SHALL INNOVATIVE TELECOMMUNICATION TECHNOLOGY (INVOTEL) BE LIABLE FOR LOSS OF PROFITS OR BENEFITS, INDIRECT, SPECIAL, CONSEQUENTIAL OR OTHERWISE ARISING FROM ANY BREACH OF THIS WARRANTY OR OTHERWISE.



1112 Montana Ave Suite 250 Santa Monica, CA 90403 USA
Toll-Free: 800-747-0708 Tel: 310-899-0078 Fax: 310-899-0227 http://www.invotel.com

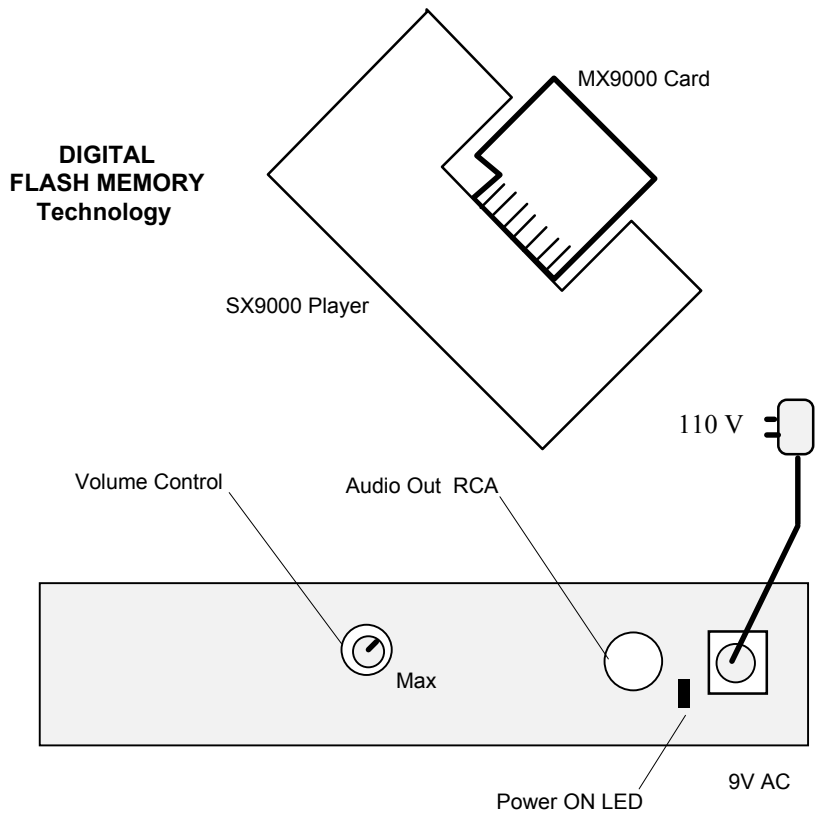

Audio playback starts automatically as soon as the power is connected, the Green LED light turns On to indicate the device is ON and is playing.

Package Content

SX9000 Digital Player Unit

Power Adapter 110v AC to 9V AC 100 ma

RCA to RCA audio cord 6 feet long

User's Manual

MX9000 True Audio Card (optional)

MX9000 Card “True Audio Card”

The MX9000 card is a Flash card that has been pre-recorded with the audio files prior to your installation and it holds the audio all the time even if power is removed. When the power is restored the play back automatically resumes from the MX9000 card.

Make sure the power is OFF prior to inserting this card into the slot.

If you need to re-install the MX9000 card or install another MX9000 card be sure to remove the power by un plugging the 9V from the player, then Install the new MX9000 card

Unlike other Flash based cards that compress the audio, voice and audio signals are stored directly into solid state memory in the MX9000 card in their natural, un-compressed form, providing superior quality voice and music reproduction. MX9000 card has 100 -year retention time at zero power and can be re-recorded 100,000 times.

Adjusting Output Level

Use the Volume control to adjust the output level. If the Music On Hold volume is too low turn the Volume control clockwise; If the Music On Hold sounds too loud turn the Volume control counter clockwise to desired level.

[please note some music titles are not royalty-free and you may want to use the royalty-free music titles to avoid annual licensing payments to ASCAP and BMI for playing those titles on-hold]

Specifications

File Formats

Supports any sound file format such as Windows .wav, MP3, WMA etc.

Frequency response 150Hz to 14.4 KHz.

Sampling rate

Supports both 8-bit and 16-bit uncompressed PCM sampled at 8, 11, 12, 16, 22, 24, 32, 44 & 48 KHz

Distortion less than 0.5% THD

Audio Quality

Supports better than CD Quality at 188 KB/s

Special effects:

Supports Windows Media Files and SRS WOW Effects

Memory Capacity (MX9000 card)

1 to 16 minutes

Maximum audio storage 8 minutes 40 seconds @ full 188 KB/s sample rate.

Memory Type (MX9000 card)

Multi-level Flash, 100 years retention time at no power, 100K re-recordable

Playback Auto-repeat

Message loading

Direct via MX9000 card

Power supply

110VAC 60 Hz. To 9VAC 100ma

Audio output

Mono RCA jack, Adjustable volume, 1.5V p-p @ 8Ω , 3V p-p @ 600Ω

Size 4" x 2" x 0.9" (L x W x H) **MX9000** 1.5" x 1.5" x 0.37"

Color Black

Weight 0.2 pounds (0.50 pounds with power supply)