

## Problems

## Possible Cause / Solution

Player not working or stopped working

- Unplug the power connector wait 30 seconds then plug it back in. make sure the connector is plugged in securely. Be sure to turn ON the player and observe the Status LED is Blinking ON and OFF
- Check RCA audio cord; try re-inserting it again, adjust the volume

Player does not turn ON or does not turn OFF

- Unplug the power connector then slide out the battery cover toward the USB connector and **remove the AAA battery**, wait 30 seconds, then insert the battery, the cover and power, then try again.

Cannot Transfer files to player

- If you use Windows 98 SE, ensure to use USB driver is installed properly in your system.
- Ensure the player is connected securely to your PC USB port, or to the supplied USB cable, try another USB port directly or another cable, Ensure to observe that the Status LED turns ON solid when you connect the player to your PC USB port.

Audio Volume is too low

- Verify that the audio cord is plugged in securely, Press and Hold the Volume up button. Have your dealer email you a new "full volume" MP3 file. In some older phone systems you may need to adjust the internal volume control in your phone system. Use an external "MOH amplifier" such as part number SX9500A

## Warranty

This product is warranted against defects for a period of Three (3) years from the date of original invoice. We will repair/replace the product with no charge for parts or labor within this time. To obtain warranty service the product needs to be returned freight prepaid by the customer with a copy of original invoice. This warranty does not apply if in the sole opinion of Innovative Telecommunication Technology LLC, the product has been tampered with or damaged by lightning or any other acts of nature, misuse, neglect or unauthorized service.

EXCEPT AS SPECIFICALLY PROVIDED IN THIS AGREEMENT, THERE ARE NO OTHER WARRANTIES, EXPRESSED OR OTHERWISE, INCLUDING, BUT NOT LIMITED TO ANY IMPLIED WARRANTIES OR MERCHANTABILITY OR FITNESS FOR A SPECIAL PURPOSE. IN NO EVENT SHALL INNOVATIVE TELECOMMUNICATION TECHNOLOGY LLC (INVOTEL) BE LIABLE FOR LOSS OF PROFITS OR BENEFITS, INDIRECT, SPECIAL, CONSEQUENTIAL OR OTHERWISE ARISING FROM ANY BREACH OF THIS WARRANTY OR OTHERWISE.

# invotel®

1112 Montana Ave Suite 250 Santa Monica, CA 90403 USA  
Tel: 310-899-0078 Fax: 310-857-6401 <http://www.invotel.com>



## User Manual Invotel USB 120M Music On Hold Digital MP3 Player

Rev 04

- Install the player near the phone system MOH jack using the provided Velcro
- Connect the Audio Out to the "Audio & Power" cord as shown
- Connect the RCA (RED) jack to your phone system MOH jack using the provided RCA-RCA cable (use the RCA to Mono plug adapter if needed)
- Plug the AC adapter. (110V AC to 6VDC) to power outlet.
- **Turn On the Player** : Press the ON/OFF button (about 5 seconds) until the LED turns ON, now **press it again** once to start the play back- LED begins to BLINK to indicate playing
- Adjust Volume level up or down as needed

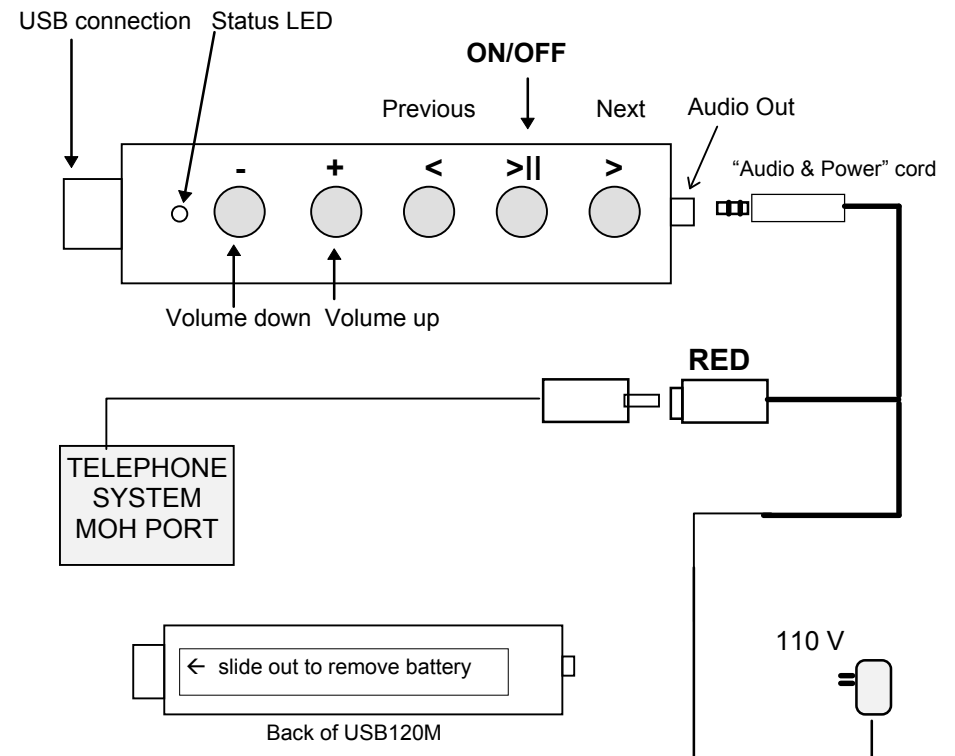

## Package Content:

USB 120M or USB 240M MP3 Digital Player unit  
Power adapter 110v AC to 3-6V DC 100 to 200 ma  
USB cord to connect the player to PC for file loading  
"audio & power" cord 6 feet long with RCA male to connect to MOH port  
RCA female to Mono male adapter plug  
Earphone to monitor the playback  
User's Manual

## Connecting to a Computer:

**Step 1** Unplug the player from the "Audio & Power" cord, and turn it OFF:  
**Turning OFF:** press and hold the ON/OFF button till status LED turns OFF

**Step 2** Remove the USB cap and plug the player directly into your computer's USB port, or use the provided USB cable. **Using the provided USB cable allows updates without the need to bend over to reach the PC USB port,** you may tape the cable on your desk for future use.

The Status LED turns ON (the player uses the PC power at this time)  
The player will be detected as "Removable Disk" when you open "My Computer" or "Windows Explorer"

## Transferring Files into Player:

Select the file you want to transfer to the player and drag-and-drop it into the "Removable Disk" that represents this player (Right click on the file, Copy, move the mouse to the "Removable Disk", Right click there and Paste)

Make sure only one file is in the player. You can do this by transferring the file from the player to your PC 1<sup>st</sup> if you still want to keep it or just delete the file before transferring the new file.

## Keeping Multiple files in the USB 120M / USB 240M player:

You may keep up to 120 minutes (240 minutes in USB240M) of audio in the player in multiple files, The player will play the active files only one by one continuously,

Just make sure one file is active as follows:  
Select the desired file, then Right click on it, Click on Properties, select or remove Hidden, Apply, OK

for example: contents of "Removable Disk" is as follows:

## Normal Production1.mp3

Normal production2.mp3

Holiday Production.mp3

The inactive files are grayed-out, and will not play. They can stay in the player

Normal Production1.mp3

Normal production2.mp3

**Holiday Production.mp3**

During the Holidays simply activate the Holiday file (remove Hidden selection in properties) then inactivate the other files(select Hidden in properties)

## Do Not Disconnect the Player from USB

## Disconnecting from Computer:

1. Double click on the green arrow in the Taskbar located on the lower -right side of the computer screen(Safely Remove Hardware) 
2. Select "USB Mass Storage Device" from the list that appears then click "Stop" then press "OK", the Status LED turns OFF on the player.
3. When the "Safe to Remove Hardware" appears click OK and disconnect the player from your PC. Put the cap back ON

**To hear the audio:** After disconnecting the player from USB, you may use the provided earphone to hear the audio playback before connecting the player to your MOH jack, To do this **connect the earphone directly into Audio Out** jack on the player, turn ON the player, start the playback (Status LED blinking) There is enough power in the player to let you play and hear the audio. **Be sure to turn OFF player before connecting power to it.**

## Specifications:

**File Formats** MP3, WMA, MAC, etc.

**Frequency response** 20Hz to 20 KHz. less than 0.1% THD

**Sampling rate** >64kbps Mono, 128kbps recommended

**PC Interface** USB 2.0 Hi-Speed(MSC)

**Memory Capacity** **128MB** 120 minutes (256MB 240 minutes on USB 240M)

**Power supply:** 110VAC 60 Hz. To 6 V DC 100-200ma

**Size:** 3.5" x 1.5" x 1" (L x W x H)

**Color:** Black **Weight:** 0.1 pounds (1/2 pounds with power supply)